

# Home Automatic Washers

Refer to Page 4 for Model Numbers

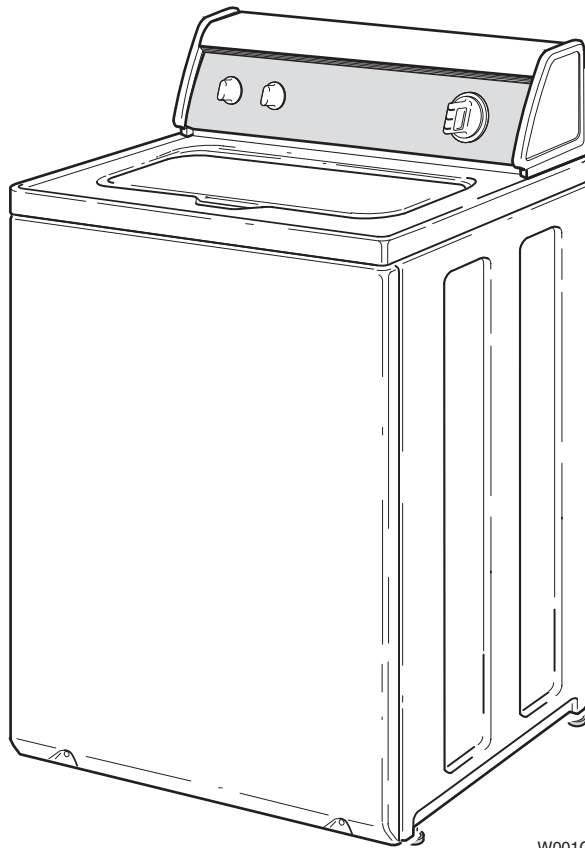

W001C

— Troubleshooting —



# Table of Contents

<b>Section 1 – Safety Information .....</b>	<b>2</b>
Locating an Authorized Servicer.....	3
<b>Section 2 – Introduction .....</b>	<b>4</b>
Model Identification .....	4
How Your Washer Works .....	5
Customer Service.....	7
Nameplate Location.....	7
<b>Section 3 – Troubleshooting.....</b>	<b>8</b>
1. No Hot Water .....	9
2. No Cold Water .....	10
3. No Warm Water .....	11
4. Water Fill Does Not Stop At Proper Level.....	12
5. Timer Does Not Advance .....	13
6. Motor Does Not Run.....	14
7. No Agitation.....	15
8. Constant Agitation .....	16
9. Washer Overheats, Cycles On Motor Thermal Protector, Switch Actuator Kicks In And Out .....	17
10. Slow Spin .....	18
11. No Spin .....	19
12. Constant Spin .....	20
13. Washer Stops In Cycle; Quits After A Couple Loads; Is Intermittent.....	21
14. Washer Is Locked Up Or Binding.....	22
15. Outer Tub Does Not Empty .....	23
16. Excessive Vibration .....	24
17. Water Leaking From Outer Tub.....	25
<b>Section 4 – Adjustments .....</b>	<b>26</b>
18. Leveling Legs.....	26
19. Pressure Switch.....	27
20. Belt (Agitate And Spin) .....	27
<b>Section 5 – Test Procedures .....</b>	<b>28</b>
21. Motor Test Procedure.....	28
22. Mixing Valve Solenoid Test Procedure.....	29
23. Temperature Switch Test Procedure .....	29
<b>Section 6 – Cycle Sequence Charts.....</b>	<b>30</b>
Timer No. 37927 Cycle Sequence .....	30
Timer No. 37929 Cycle Sequence .....	31
Timer No. 200927P Cycle Sequence .....	32
Timer No. 201101 Cycle Sequence .....	33
Timer No. 201100 Cycle Sequence .....	34

© Copyright 2007, Alliance Laundry Systems LLC

All rights reserved. No part of the contents of this book may be reproduced or transmitted in any form or by any means without the expressed written consent of the publisher.

# Section 1

## Safety Information

Throughout this manual and on machine decals, you will find precautionary statements (“CAUTION,” “WARNING” and “DANGER”) followed by specific instructions. These precautions are intended for the personal safety of the operator, user, servicer, and those maintaining the machine.

### **▲ DANGER**

Danger indicates an imminently hazardous situation that, if not avoided, will cause severe personal injury or death.

### **▲ WARNING**

Warning indicates a hazardous situation that, if not avoided, could cause severe personal injury or death.

### **▲ CAUTION**

Caution indicates a hazardous situation that, if not avoided, may cause minor or moderate personal injury or property damage.

Additional precautionary statements (“IMPORTANT” and “NOTE”) are followed by specific instructions.

### **IMPORTANT**

The word “IMPORTANT” is used to inform the reader of specific procedures where minor machine damage will occur if the procedure is not followed.

### **NOTE**

The word “NOTE” is used to communicate installation, operation, maintenance or servicing information that is important but not hazard related.

In the interest of safety, some general precautions relating to the operation of this machine follow.

	<b>WARNING</b>
<ul style="list-style-type: none"><li>• <b>Failure to install, maintain and/or operate this product according to the manufacturer’s instructions may result in conditions which can produce serious injury, death and/or property damage.</b></li><li>• <b>Do not repair or replace any part of the product or attempt any servicing unless specifically recommended or published in this Service Manual and unless you understand and have the skills to carry out the servicing.</b></li><li>• <b>Whenever ground wires are removed during servicing, these ground wires must be reconnected to ensure that the product is properly grounded and to reduce the risk of fire, electric shock, serious injury or death.</b></li></ul>	
<small>W006R2</small>	



## WARNING

To reduce the risk of electric shock, fire, explosion, serious injury or death:

- Disconnect electric power to the washer before servicing.
- Never start the washer with any guards/panels removed.
- Whenever ground wires are removed during servicing, these ground wires must be reconnected to ensure that the washer is properly grounded.

W003



## WARNING

Repairs that are made to your products by unqualified persons can result in hazards due to improper assembly or adjustments subjecting you or the inexperienced person making such repairs to the risk of serious injury, electrical shock or death.

W007



## WARNING

If you or an unqualified person perform service on your product, you must assume the responsibility for any personal injury or property damage which may result. The manufacturer will not be responsible for any injury or property damage arising from improper service and/or service procedures.

W008

**NOTE:** The WARNINGS and IMPORTANT INSTRUCTIONS appearing in this manual are not meant to cover all possible conditions and situations that may occur. Common sense, caution and care must be exercised when installing, maintaining or operating the machine.

Always contact your dealer, distributor, service agent or the manufacturer about any problems or conditions you do not understand.

### Locating an Authorized Servicer

Alliance Laundry Systems is not responsible for personal injury or property damage resulting from improper service. Review all service information before beginning repairs.

Warranty service must be performed by an authorized technician, using authorized factory parts. If service is required after the warranty expires, Alliance Laundry Systems also recommends contacting an authorized technician and using authorized factory parts.

# Section 2

## Introduction

### Model Identification

Information in this manual is applicable to these washer models.

Model Number	1 Speed Motor	2 Speed Motor	3 Speed Motor	Porcelain Washtub (cu. ft.)	Stainless Steel Washtub (cu. ft.)
LWS01A*	X			2.9	
LWS01A*C	X			2.9	
LWS01B*	X			2.9	
LWS01M*	X			2.9	
LWS01N*	X			2.9	
LWS02A*	X			3.3	
LWS02B*	X			3.3	
LWS02M*	X			3.3	
LWS02N*	X			3.3	
LWS04M*	X				3.3
LWS04N*	X				3.3
LWS05N*	X				3.3
LWS16A*	X			3.3	
LWS16B*	X			3.3	
LWS16M*	X			3.3	
LWS16N*	X			3.3	
LWS17A*	X				3.3
LWS17B*	X				3.3
LWS17M*	X				3.3
LWS17N*	X				3.3
LWS44N*		X			3.3
LWS45A*		X			3.3
LWS45B*		X			3.3
LWS45M*		X			3.3
LWS45N*		X			3.3
LWS49N*		X			3.3

\* Add Letter To Designate Color. L – Almond W – White Q – Bisque

# How Your Washer Works

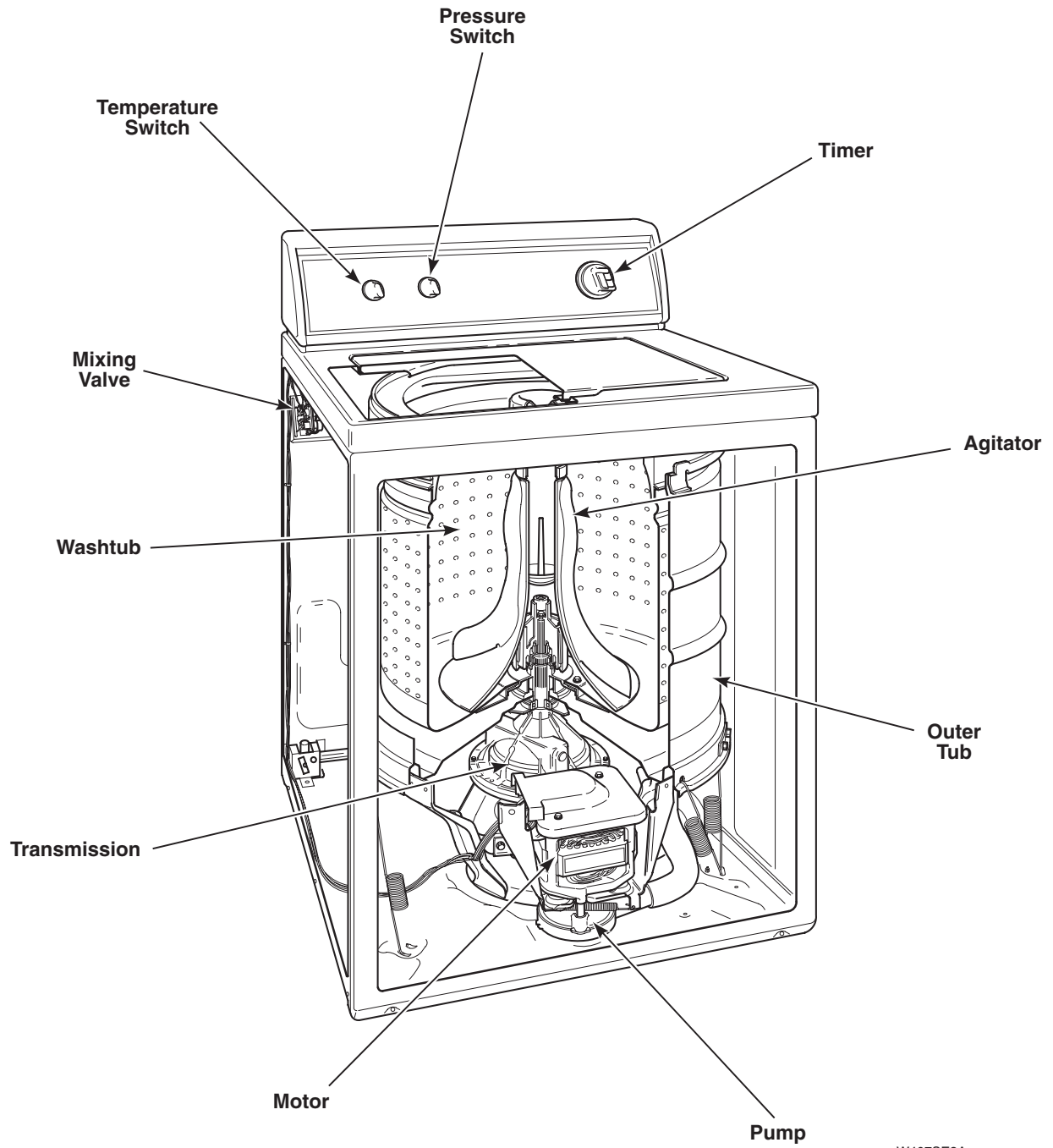

W407SE3A

## Introduction

The cycle begins with a wash fill. The water temperature is determined by the temperature selector. While water fills the washtub, a column of air is trapped in a pressure bulb and hose. The air pressure continues to increase as the washtub fills with water until it is great enough to activate the pressure switch. The pressure switch then causes the wash fill to stop and wash agitation to begin. However, the loading door must be closed for the washer to agitate or spin.

The washer uses a reversing type motor, a special drive belt and an idler assembly. The idler assembly applies tension to the outside of the drive belt.

During agitation, the motor runs in the counterclockwise direction. The spring tension on the idler pulley applies the tension required to reduce the slack on the drive belt and maintain maximum belt to motor pulley contact. This eliminates belt slippage and ensures an efficient wash action, even with extra large loads.

The belt drives the transmission drive pulley in the counterclockwise direction. The pulley drives the helix which is splined to the input shaft of the transmission. This causes the input shaft to turn inside of a roller clutch which is pressed into the transmission cover. This roller clutch acts as a bearing in the counterclockwise direction allowing the transmission gears to operate. The transmission's rack and pinion gear design produces a 210 degree agitation stroke at the output shaft of the transmission which drives the agitator. The brake assembly remains locked during the agitation mode since no pressure is applied to it by the transmission drive pulley.

After the wash agitation is completed, the timer advances into the first spin. During spin, the motor reverses turning in the clockwise direction to spin the water out of the washtub. The combination of water, washtub and load weight cause the drive belt tension on the idler side of the belt to overtake the idler spring pressure allowing the belt to become slack on the opposite side. This reduces the belt to pulley contact and allows slipping between the belt and pulley.

As water is removed by the pump and the momentum of the washtub increases, the idler spring tension gradually overcomes the belt tension removing the belt slack. This eventually increases the belt to pulley contact until maximum spin speed is achieved.

The drive pulley turns clockwise riding up the ramps of the helix, exerting pressure on the brake and forcing it to release from brake pads. The helix drives the input shaft of the transmission, and when the input shaft turns in the clockwise direction the roller clutch locks onto the shaft causing the entire transmission assembly to turn. None of the gears in the transmission are operating at this time. The hub of the washtub is splined to the transmission tube and rotates with the transmission assembly. The centrifugal force created by the spinning washtub causes water to be extracted from the clothes.

Water is introduced during the first spin to "SPRAY" the garments and remove suds from them. The initial spin is followed by rinse agitation to rinse away any detergent residue. The washer fills and then agitates like the wash portion of the cycle. Following rinse agitation, a final spin extracts the rinse water from the clothes preparing them for the dryer.

## Customer Service

If literature or replacement parts are required, contact the source from whom the machine was purchased or contact Alliance Laundry Systems at (920) 748-3950 for the name and address of the nearest authorized parts distributor.

For technical assistance, call (920) 748-3121.

## Nameplate Location

When calling or writing about your product, be sure to mention model and serial numbers. Model and serial numbers are located on nameplate(s) as shown.

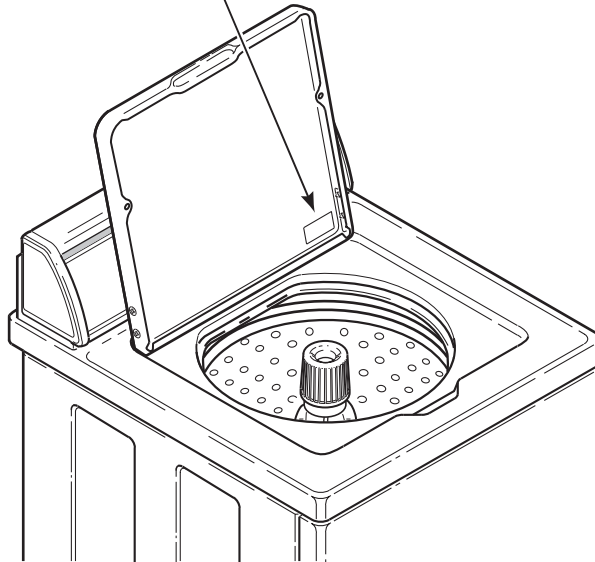

W429SE1B

# Section 3

## Troubleshooting



### WARNING

To reduce the risk of electric shock, fire, explosion, serious injury or death:

- Disconnect electric power to the washer before servicing.
- Never start the washer with any guards/panels removed.
- Whenever ground wires are removed during servicing, these ground wires must be reconnected to ensure that the washer is properly grounded.

W003

**IMPORTANT:** Refer to wiring diagram for aid in testing washer components.

# 1. No Hot Water

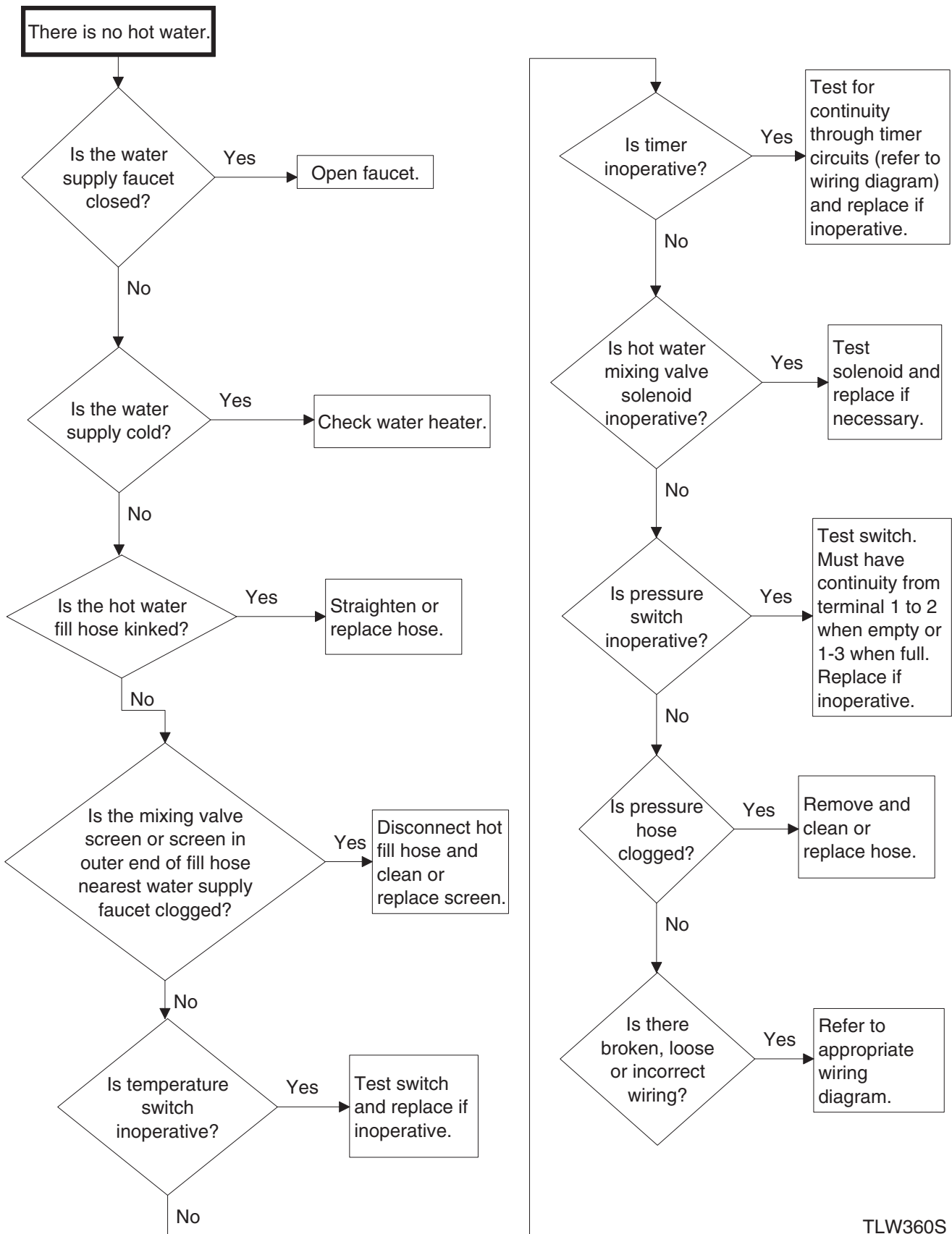

TLW360S

## 2. No Cold Water

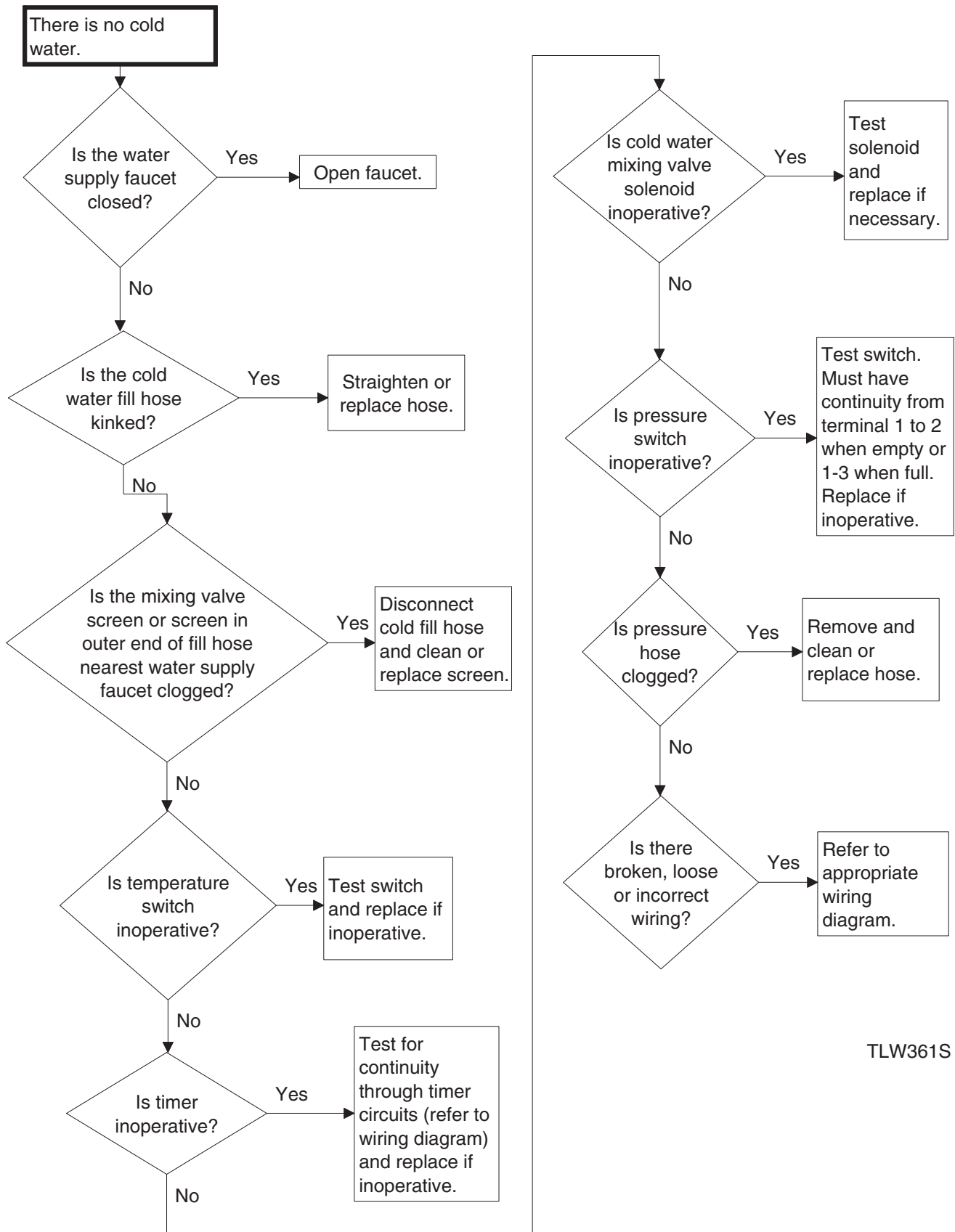

TLW361S

### 3. No Warm Water

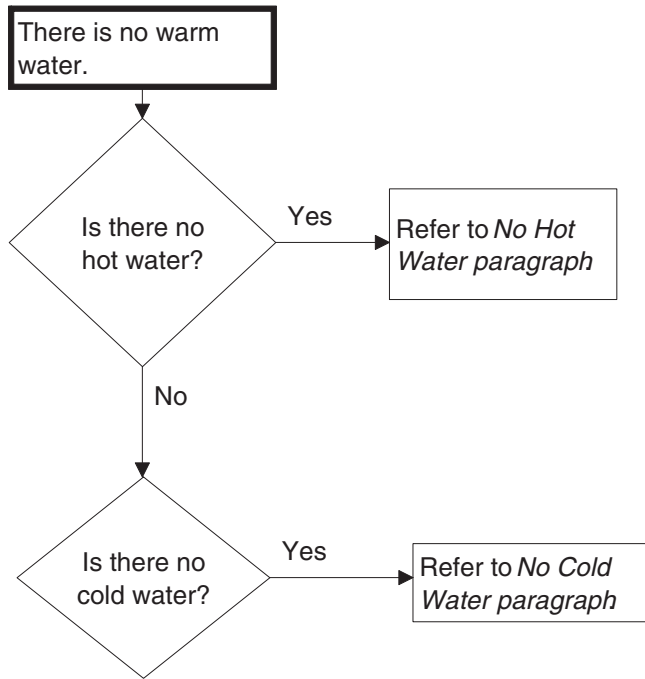

TLW362S

### 4. Water Fill Does Not Stop At Proper Level

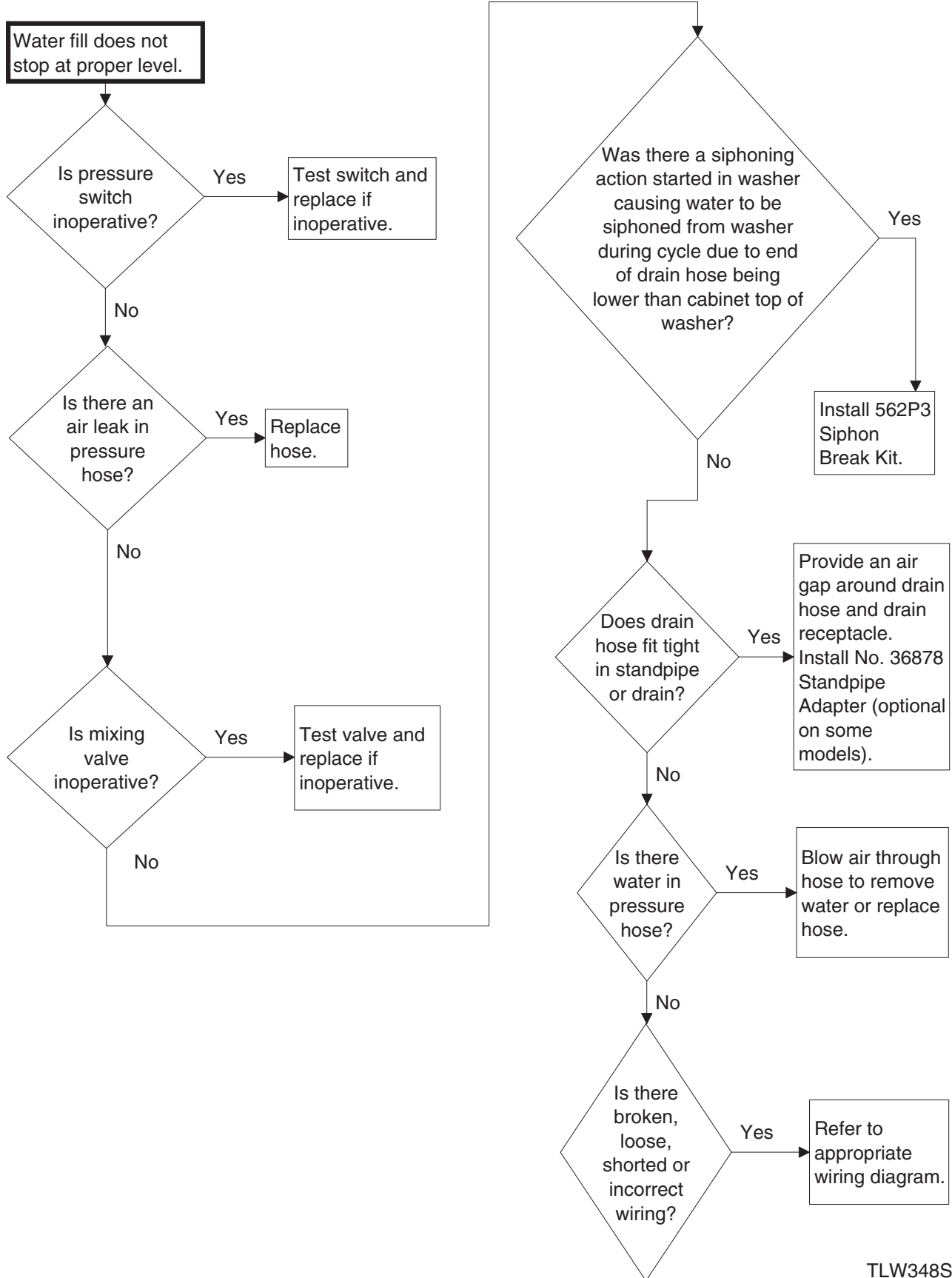

TLW348S

### 5. Timer Does Not Advance

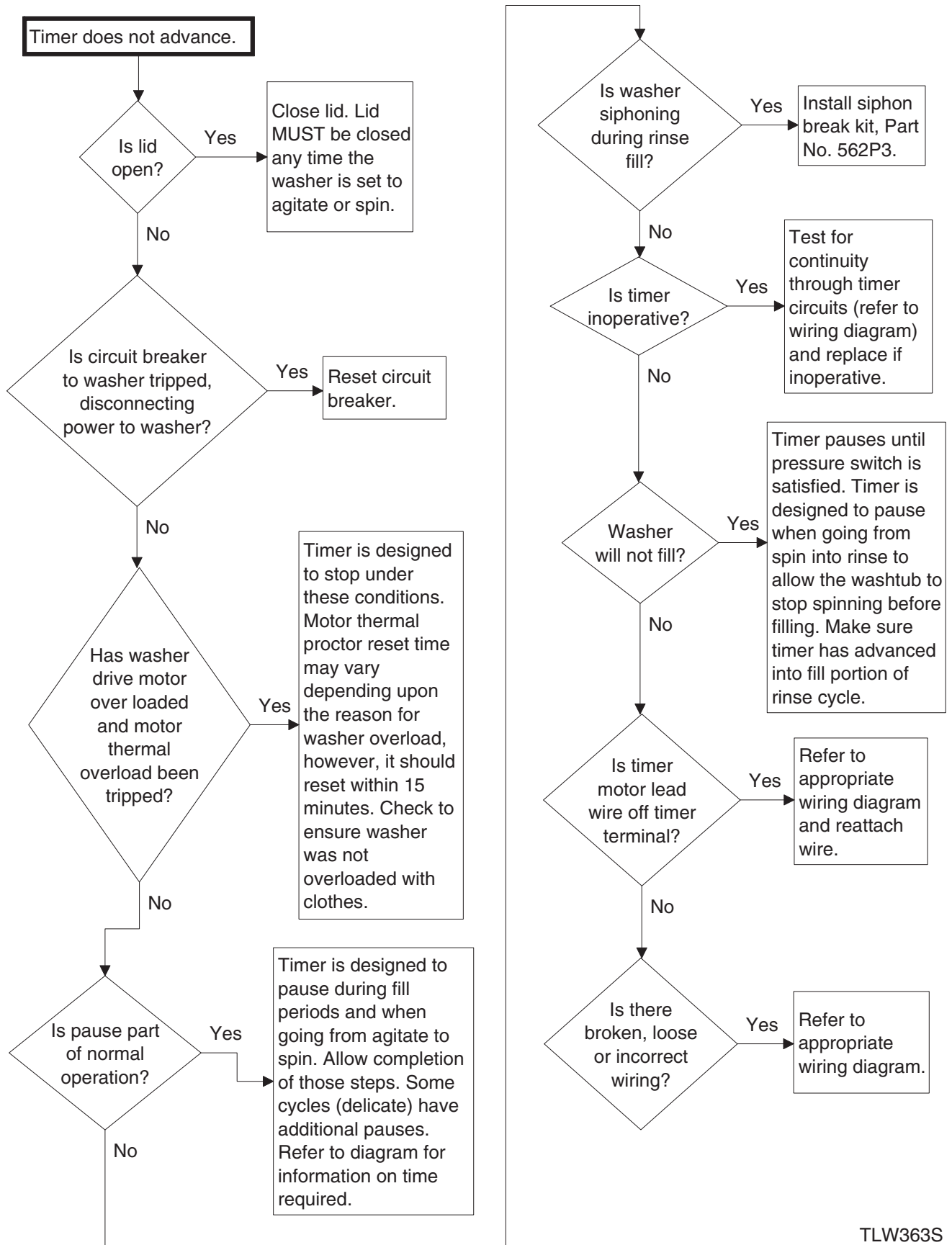

TLW363S

## 6. Motor Does Not Run

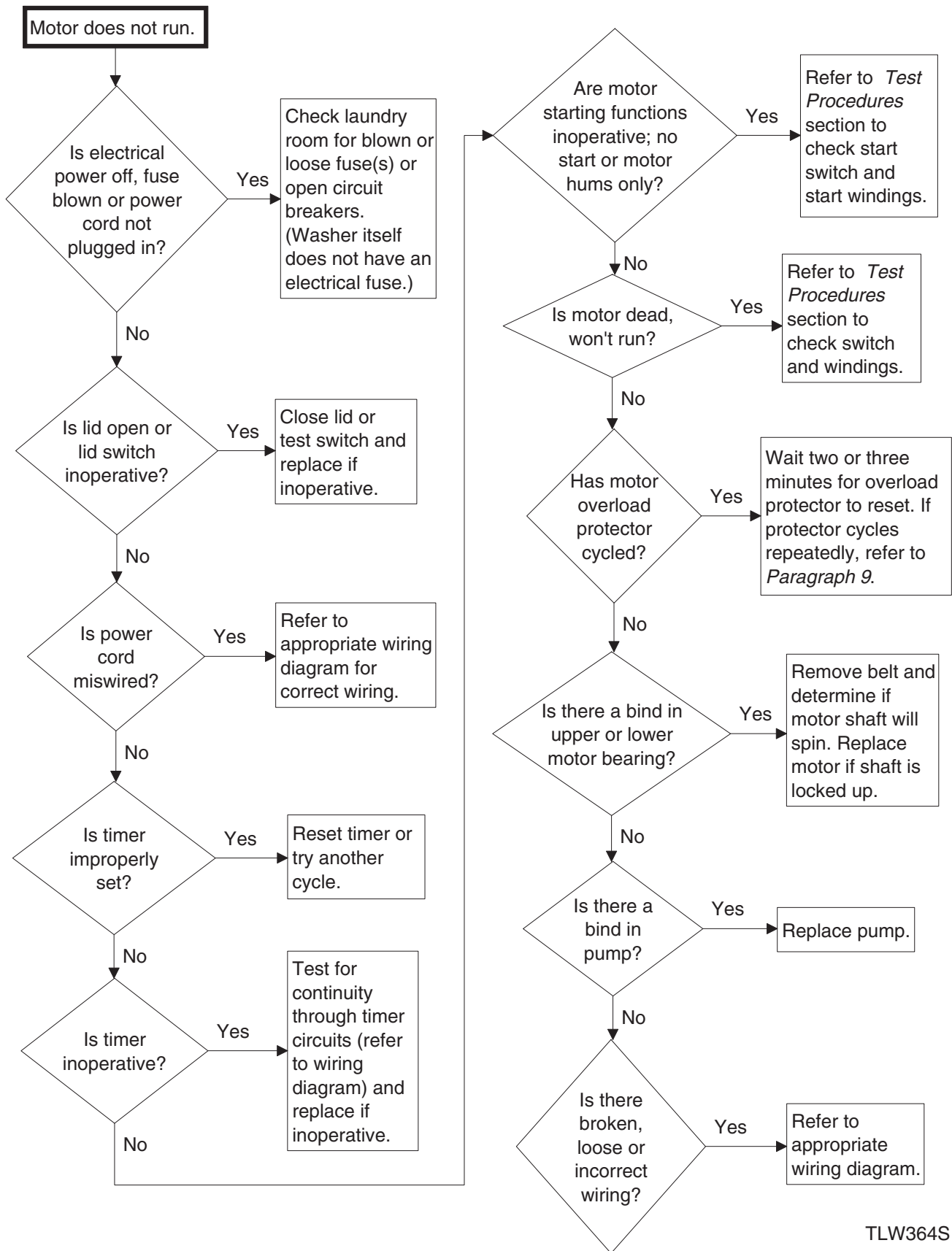

TLW364S

## 7. No Agitation

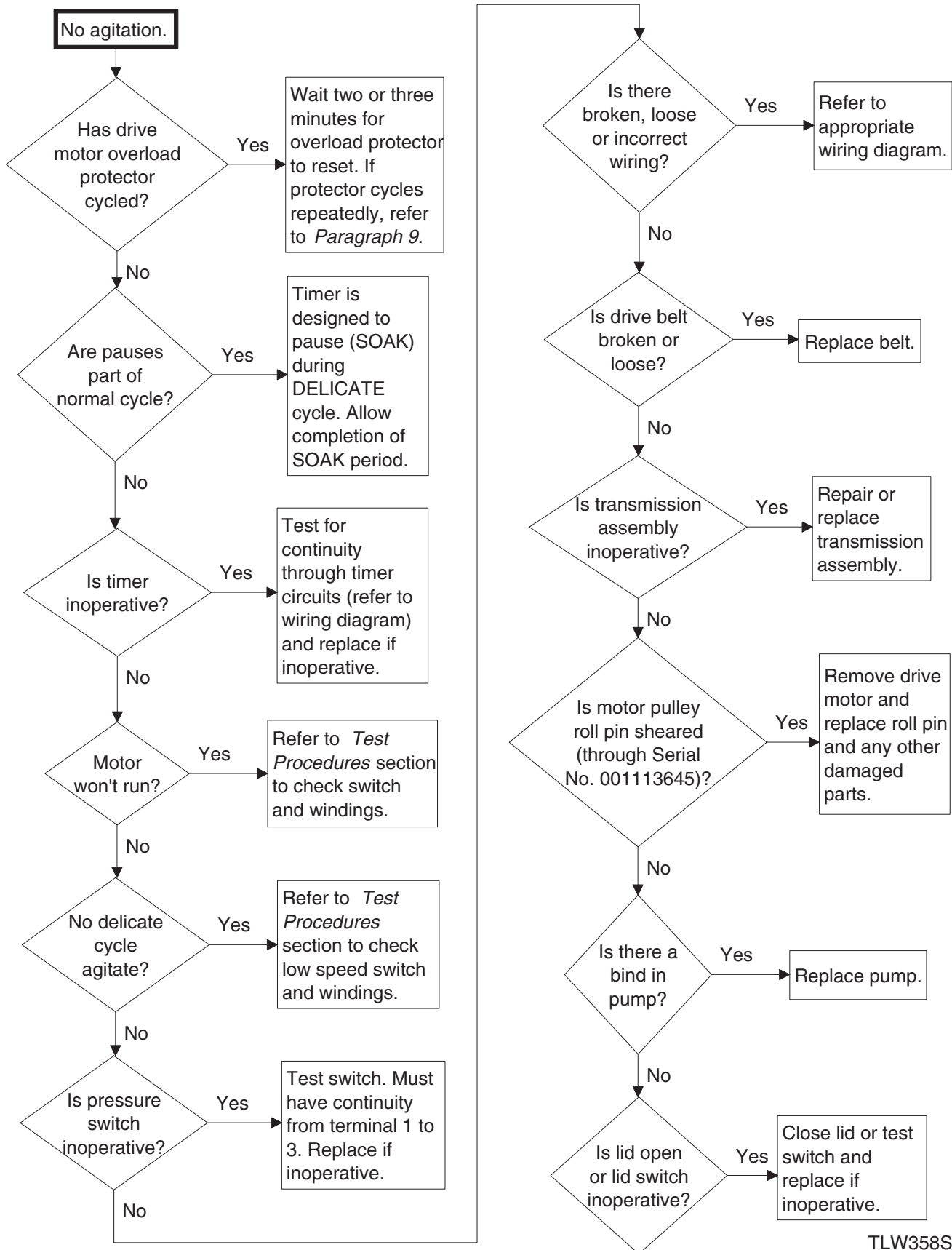

TLW358S

### 8. Constant Agitation

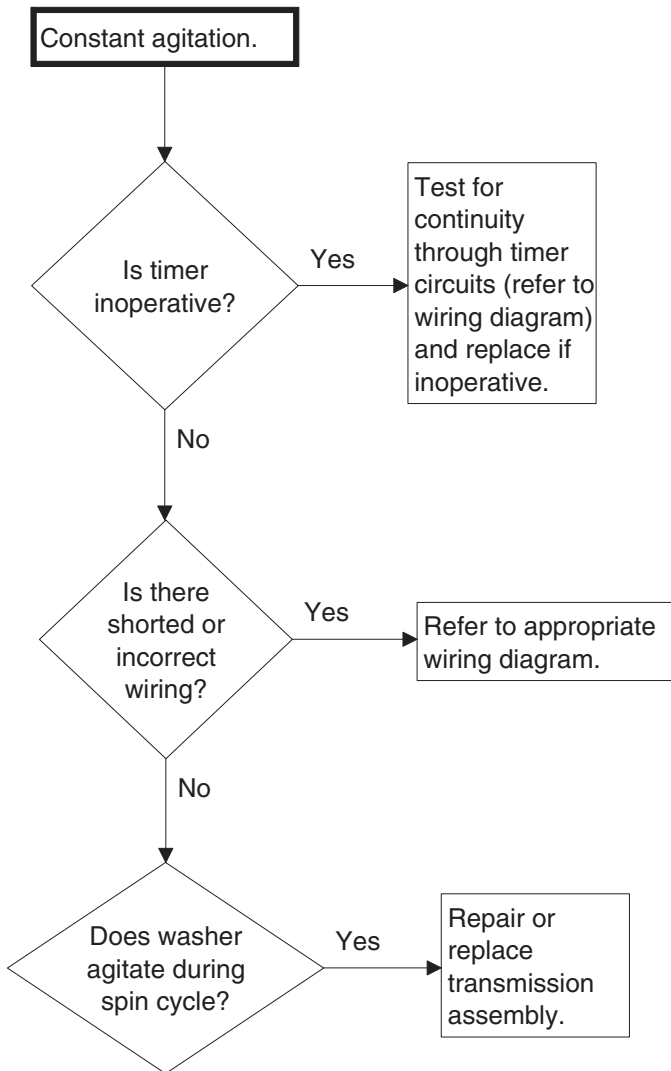

TLW365S

## 9. Washer Overheats, Cycles On Motor Thermal Protector, Switch Actuator Kicks In And Out

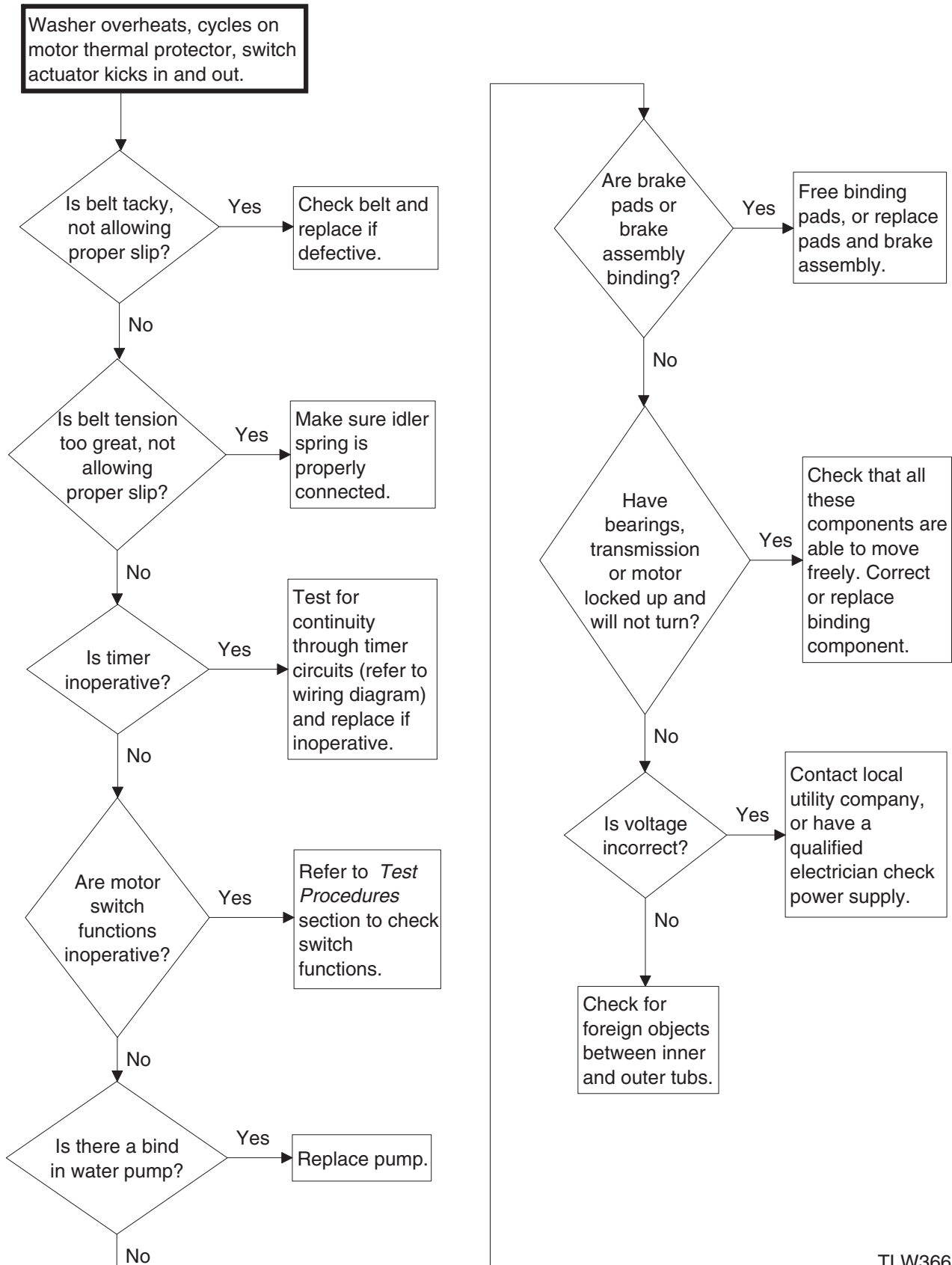

TLW366S

# 10. Slow Spin

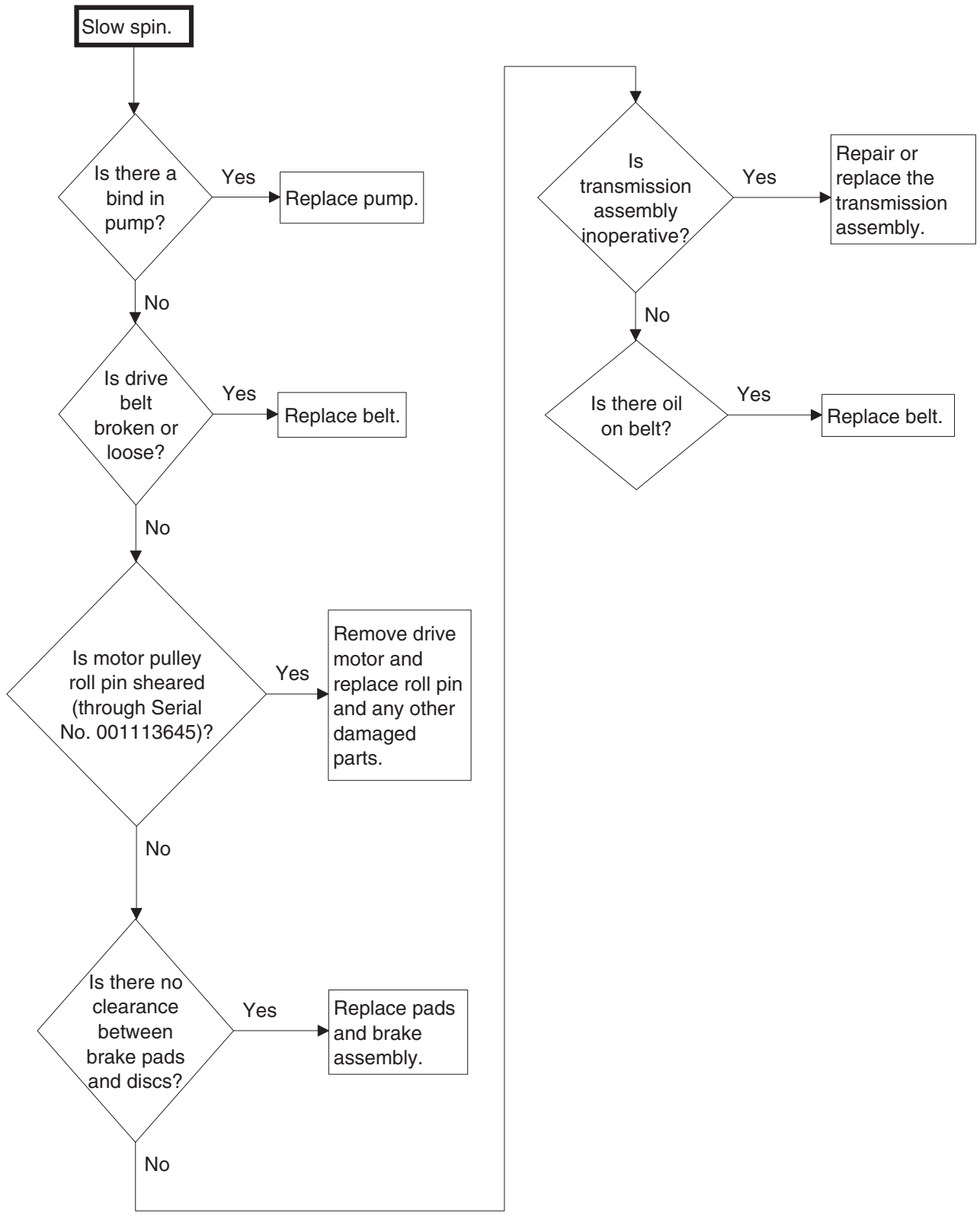

# 11. No Spin

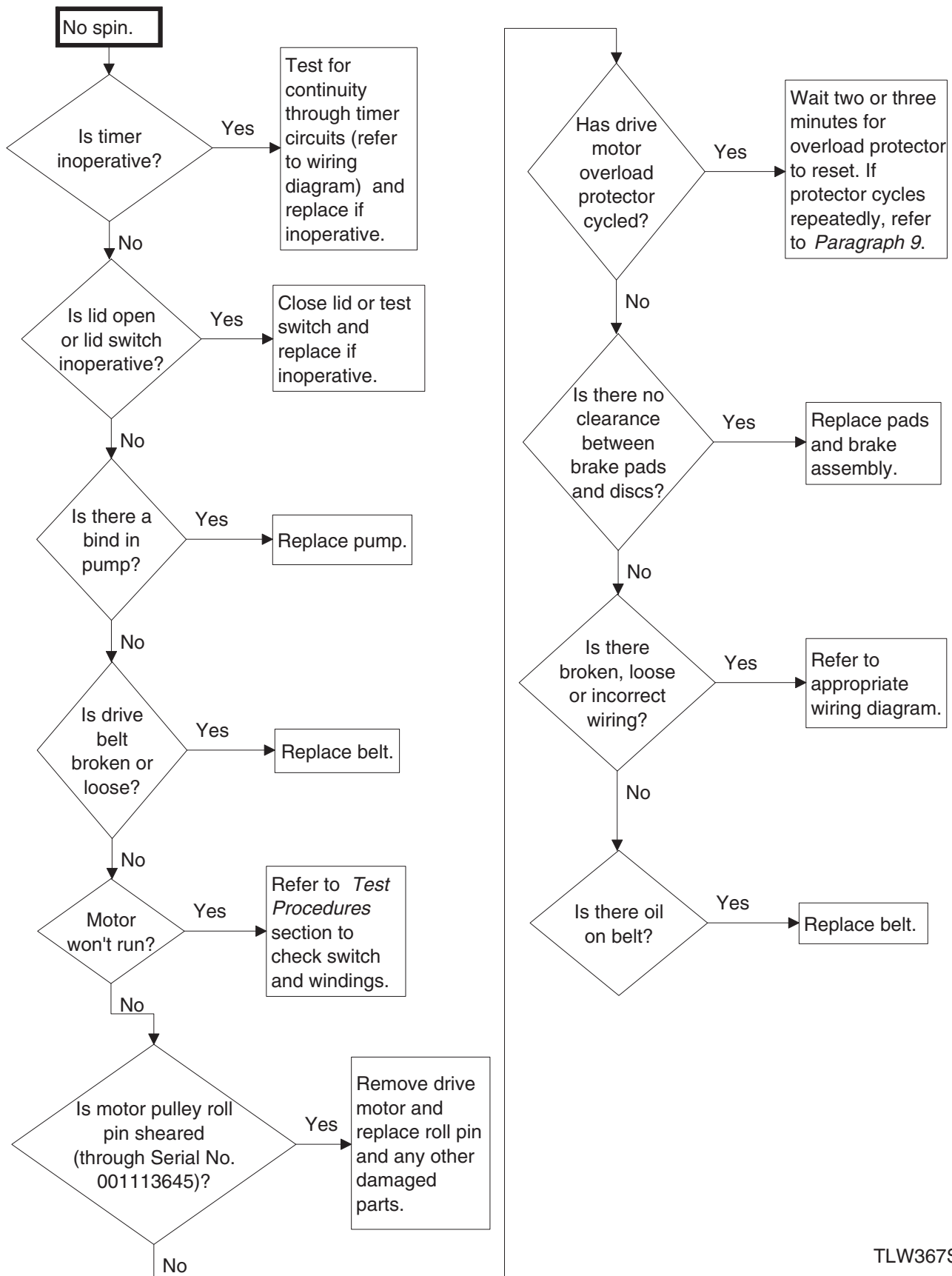

TLW367S

## 12. Constant Spin

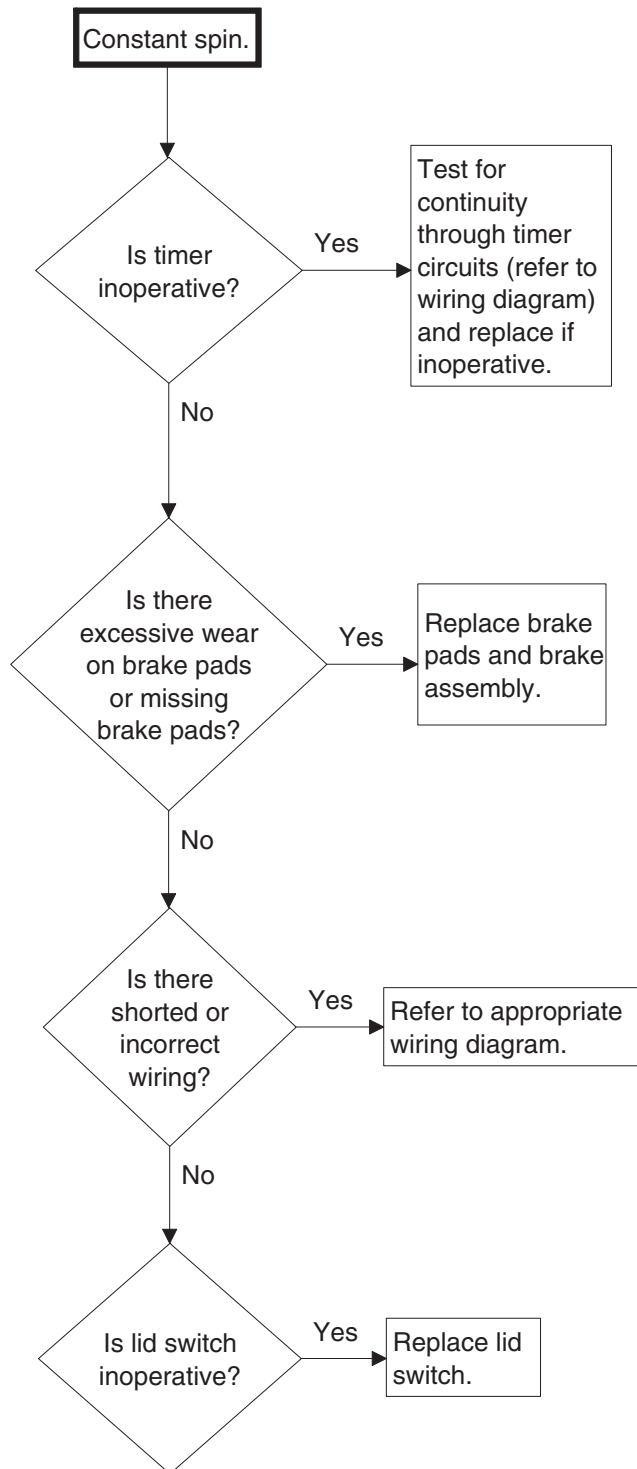

TLW368S

### 13. Washer Stops In Cycle; Quits After A Couple Loads; Is Intermittent

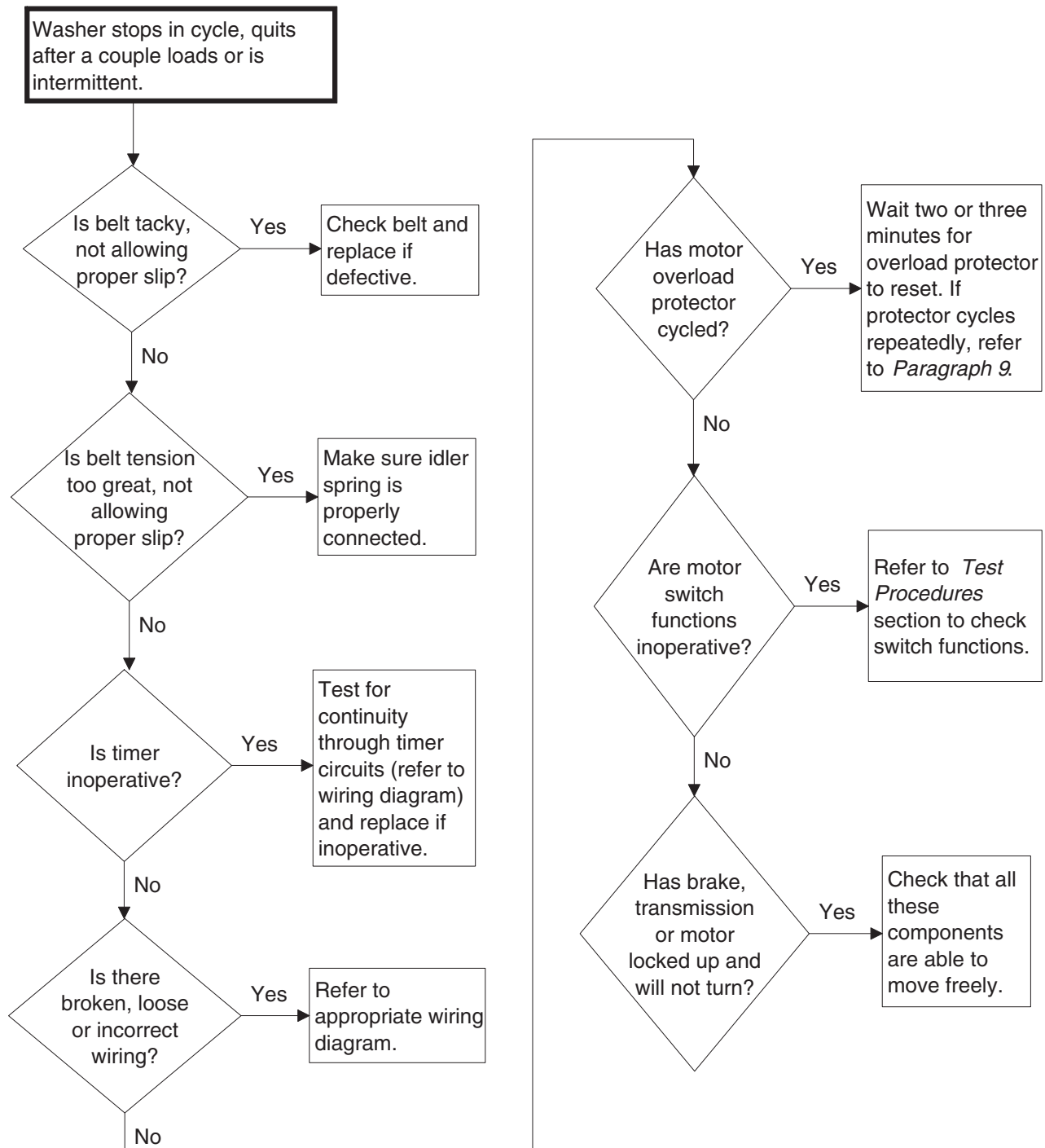

### 14. Washer Is Locked Up Or Binding

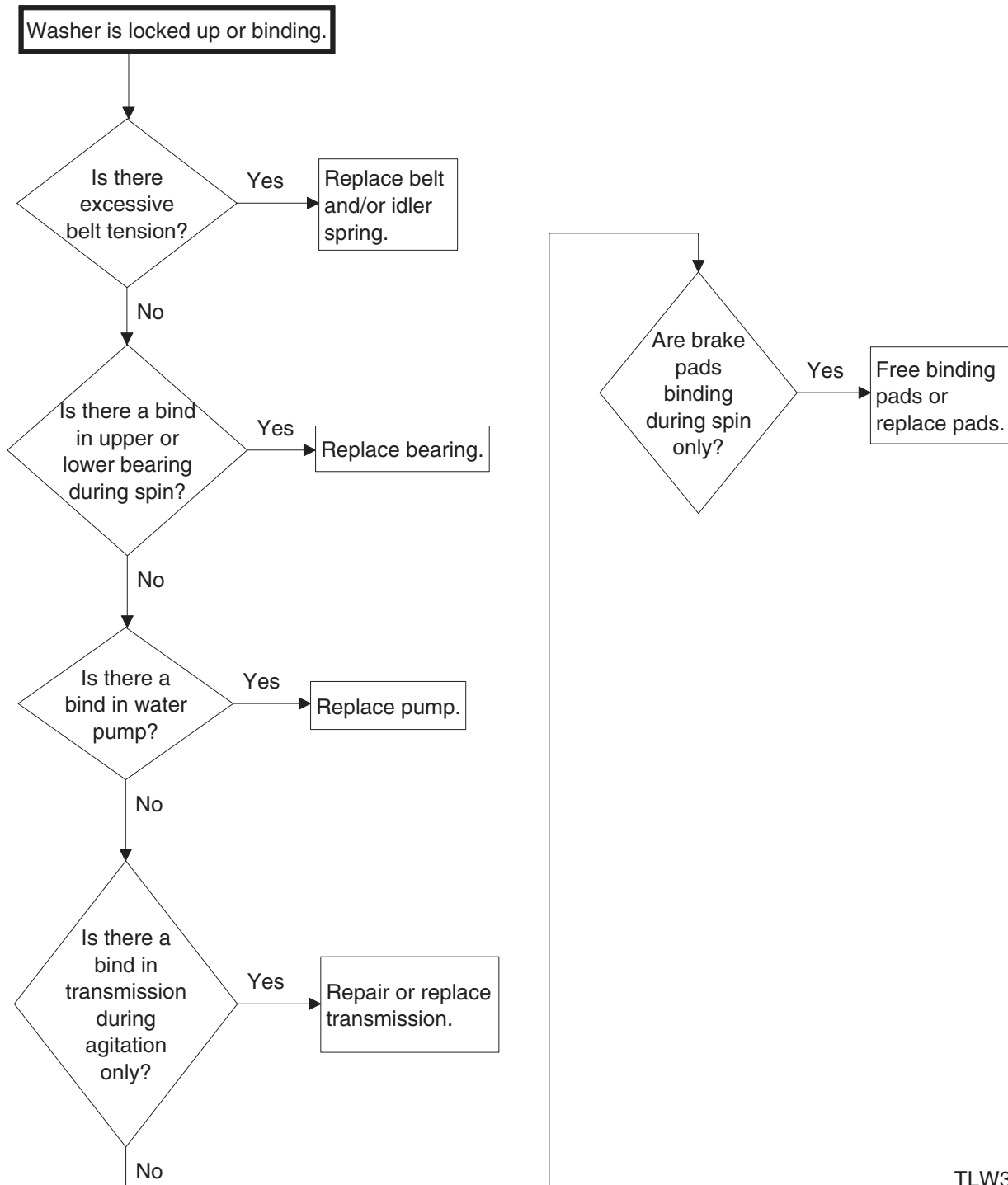

TLW369S

## 15. Outer Tub Does Not Empty

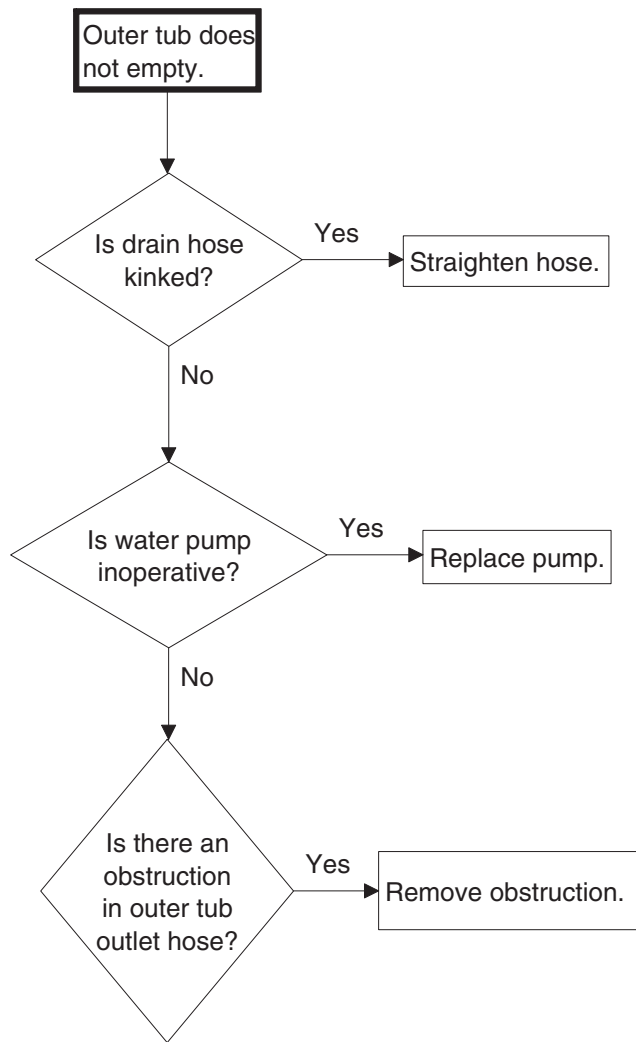

TLW370S

### 16. Excessive Vibration

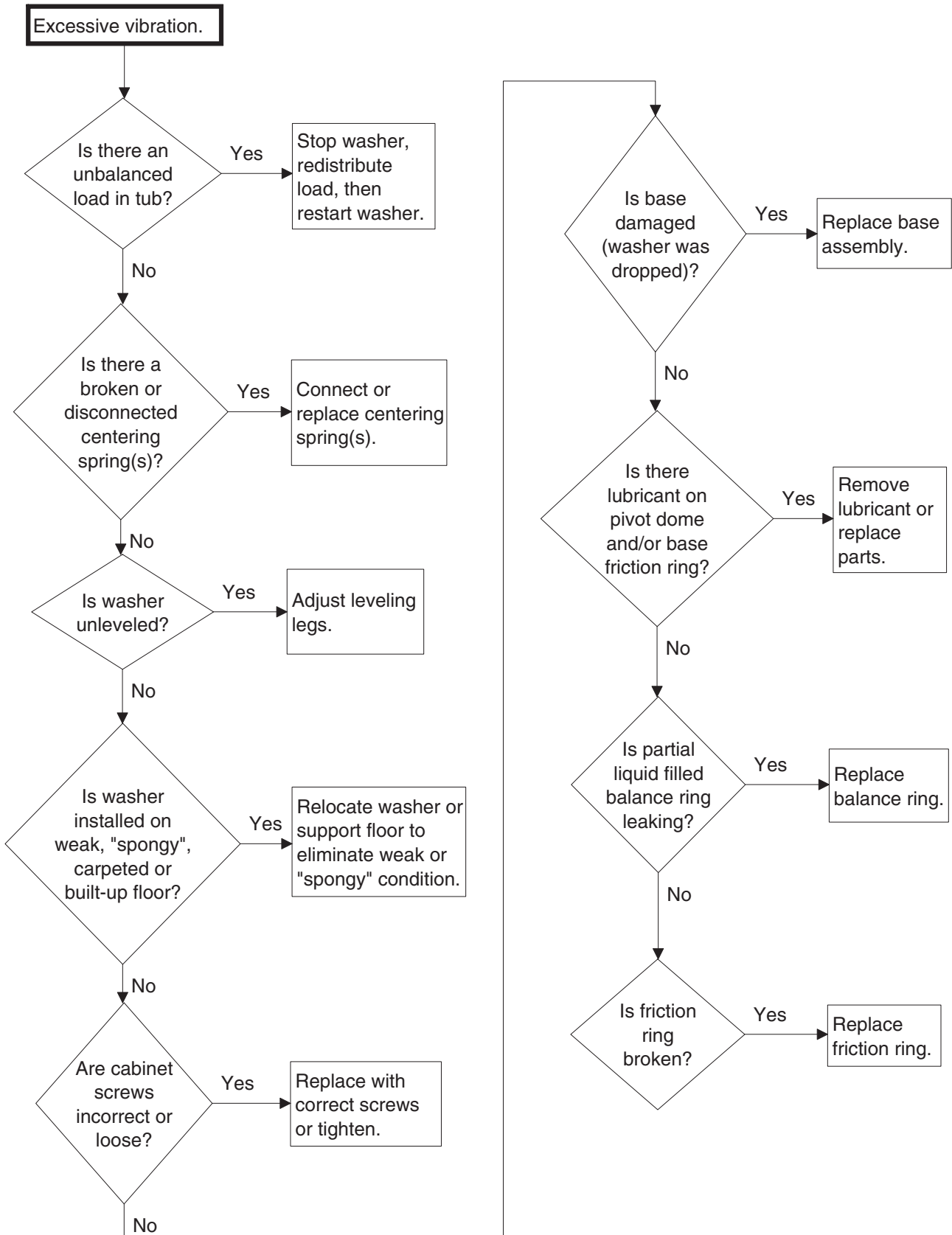

TLW357S

## 17. Water Leaking From Outer Tub

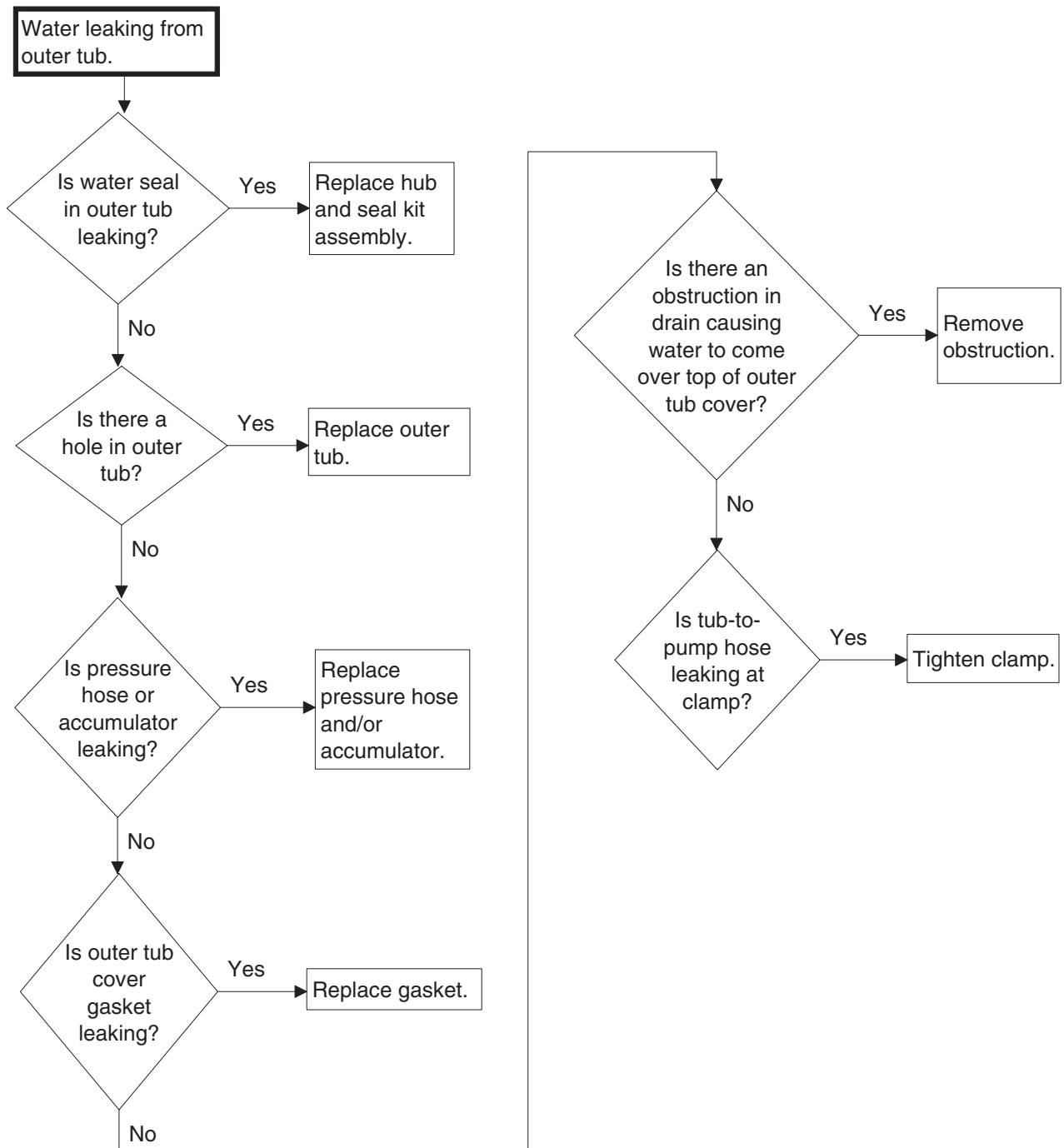

TLW341S

# Section 4 Adjustments



## WARNING

To reduce the risk of electric shock, fire, explosion, serious injury or death:

- Disconnect electric power to the washer before servicing.
- Never start the washer with any guards/panels removed.
- Whenever ground wires are removed during servicing, these ground wires must be reconnected to ensure that the washer is properly grounded.

W003

## 18. Leveling Legs

Refer to *Figure 1*.

- Place rubber feet on all four leveling legs.
- Place washer in position on a clean, dry, and reasonably firm floor.
- Loosen locknuts and adjust two front leveling legs. Once adjusted, tilt washer forward on front legs and lower back down into position to set the rear self-leveling legs.

- Washer must not rock. After washer is at desired height, tighten locknuts securely against bottom of washer base. If these locknuts are not tight, washer will not remain stationary during operation.

**NOTE: Improper installation, installation on carpet or flexing of a weak floor will cause excessive vibration.**

**IMPORTANT: Do not slide washer across floor once leveling legs have been extended, as legs and base could become damaged.**

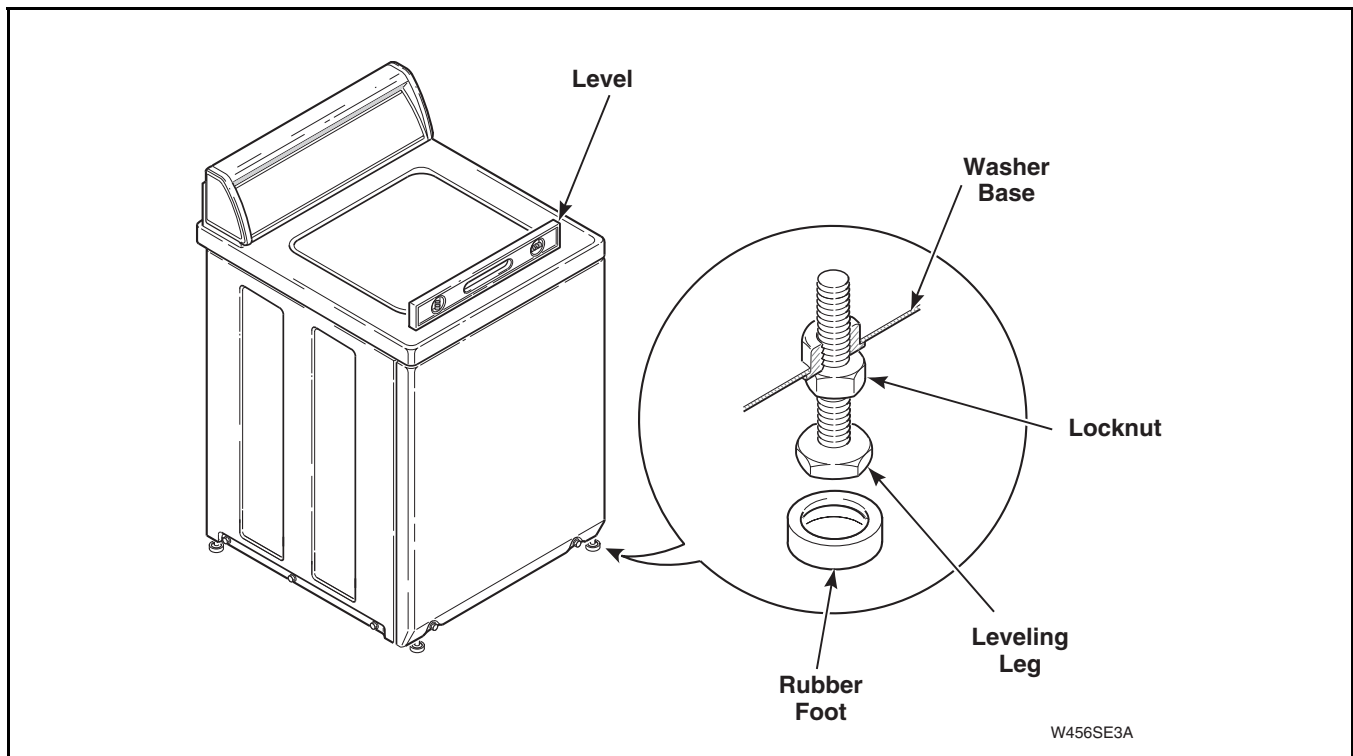

Figure 1



## WARNING

To reduce the risk of electric shock, fire, explosion, serious injury or death:

- Disconnect electric power to the washer before servicing.
- Never start the washer with any guards/panels removed.
- Whenever ground wires are removed during servicing, these ground wires must be reconnected to ensure that the washer is properly grounded.

W003

## 19. Pressure Switch

Refer to *Figure 2*.

**NOTE: DO NOT ADJUST PRESSURE SWITCH IF WASHER IS WITHIN THE WARRANTY PERIOD.**

Pressure switch is set at the factory for proper water fill levels. However, if there is a problem of overfilling or underfilling, pressure switch can be adjusted.

Maximum water fill level can be increased by turning adjusting screw **CLOCKWISE**, and decreased by turning screw **COUNTERCLOCKWISE**.

One quarter turn of the adjusting screw represents approximately one inch (25.4 mm) increase or decrease of water level in washtub.

**IMPORTANT: DO NOT** turn adjusting screw more than  $\frac{3}{4}$  of a turn in either direction as the switch may be damaged and flooding could result.

When testing, pressure switch has continuity from terminal 1 to 2 when empty and 1 to 3 when full.

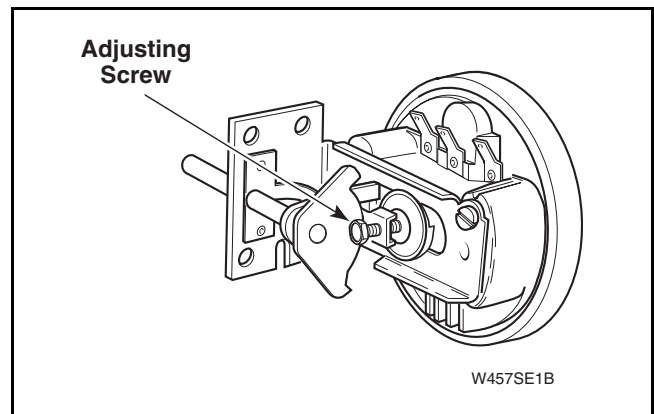



Figure 2

## 20. Belt (Agitate And Spin)

No belt adjustment is required.

# Section 5

## Test Procedures

	<b>WARNING</b>
<p>To reduce the risk of electric shock, fire, explosion, serious injury or death:</p> <ul style="list-style-type: none"> <li>• Disconnect electric power to the washer before servicing.</li> <li>• Never start the washer with any guards/panels removed.</li> <li>• Whenever ground wires are removed during servicing, these ground wires must be reconnected to ensure that the washer is properly grounded.</li> </ul>	
<small>W003</small>	

### 21. Motor Test Procedure

**IMPORTANT:** Disconnect base wire harness plug from motor.

	<b>WARNING</b>
<p><b>Disconnect electric power to washer before performing the following steps:</b></p>	
<small>W188</small>	

Motor test procedures using an Ohm meter.

**NOTE:** Resistance readings slightly out of given ranges may be due to meter conditions. These readings **DO NOT** necessarily indicate motor failure.

	Meter Connections	Reading Should Be	If Not
1.	Ground to Each Other Terminal	Open	Terminal shorted to ground.
2.	White to Yellow	Closed	Open thermal overload.
3.	Red to Brown	2-8 Ohms	Start winding open or resistance too high or too low.
4.	Blue to White	1-2 Ohms	High speed winding (4 pole) open or resistance too high or too low.
5.	Violet to White (2-speed motor)	2.5 Ohms (Approximate)	Low winding opening; High speed winding open; or resistance too high or too low.
6.	“R” to Red	Closed	Open start (auxiliary) switch.
7.	“P” to Blue (2-speed motor)	Closed	Open start switch 4 pole winding.

**NOTE:** Steps 8, 9 and 10 are with motor centrifugal mechanism in the run position.

8.	“R” to Red	Open	Start auxiliary switch.
9.	“P” to Blue (2-speed motor)	3 Ohms (approximate)	Refer to Blue to White and Violet to White.
10.	“P” to Blue (2-speed motor)	Closed	Open low (6 pole) winding run switch.



## WARNING

- To reduce the risk of electric shock, fire, explosion, serious injury or death:
- Disconnect electric power to the washer before servicing.
  - Never start the washer with any guards/panels removed.
  - Whenever ground wires are removed during servicing, these ground wires must be reconnected to ensure that the washer is properly grounded.

W003

## 22. Mixing Valve Solenoid Test Procedure

Mixing valve test procedures using an Ohm meter.

**NOTE:** Resistance readings slightly out of given ranges may be due to meter conditions. These readings **DO NOT** necessarily indicate mixing valve failure.

120 Volt coils	900 - 1100 Ohms
----------------	-----------------

## 23. Temperature Switch Test Procedure

Check for continuity between the following terminal connections:

### 3 Position Switches

Temperature		Connection
Wash	Rinse	
Hot	Cold	L - 3
Warm	Cold	L - 3- 4
Cold	Cold	L - 4

### 4 Position Switches

Temperature		Connection
Wash	Rinse	
Hot	Cold	L1 - 2
Warm	Warm	L1 - 1, L1 - 2, L2 - 2, L2 - 1, L2 - L1, 1 - 2
Warm	Cold	L1 - 2, L1 - 1, 1 - 2
Cold	Cold	L1 - 1

### 5 Position Switches

Temperature		Connection
Wash	Rinse	
Hot	Cold	L1 - 2
Hot	Warm	L1 - 2, L2 - 2
Warm	Cold	L1 - 1, L1 - 2
Warm	Warm	L1 - 1, L1 - 2, L2 - 2
Cold	Cold	L1 - 1

# Section 6 Cycle Sequence Charts

NOTE: Times listed are approximate.

CYCLE	FUNCTION	WATER TEMP. SELECT	*MOTOR SPEED	TIME (Min. & Sec.)
<b>SOAK</b>	SOAK FILL & AGITATE	H,W,C	SLOW	4:00
	SOAK FILL	H,W,C		12:00
	SPIN		SLOW	4:00
<b>OFF</b>				4:00
<b>REGULAR</b>	WASH FILL & AGITATE	H,W,C	FAST	15:30
	SPIN		FAST	2:00
	SPIN & SPRAY	C	FAST	:30
	SPIN		FAST	1:30
	RINSE FILL & AGITATE	W,C	FAST	4:00
	SPIN		FAST	6:00
<b>OFF</b>				4:00
<b>PERMANENT PRESS</b>	WASH FILL & AGITATE	H,W,C	FAST	9:30
	SPIN		SLOW	2:00
	SPIN & SPRAY	C	SLOW	:30
	SPIN		SLOW	1:30
	RINSE FILL & AGITATE	W,C	FAST	4:00
	SPIN		FAST	6:00
<b>OFF</b>				4:00
<b>DELICATE</b>	WASH FILL & SOAK	H,W,C		3:00
	WASH FILL & AGITATE	H,W,C	SLOW	:30
	WASH FILL & SOAK	H,W,C		1:30
	WASH FILL & AGITATE	H,W,C	SLOW	:30
	WASH FILL & SOAK	H,W,C		1:30
	WASH FILL & AGITATE	H,W,C	SLOW	:30
	WASH FILL & SOAK	H,W,C		1:30
	WASH FILL & AGITATE	H,W,C	SLOW	:30
	WASH FILL & SOAK	H,W,C		1:30
	SPIN		SLOW	2:00
	SPIN & SPRAY	C	SLOW	:30
	SPIN		SLOW	1:30
	RINSE FILL & AGITATE	C	SLOW	4:00
	SPIN		SLOW	4:00
	<b>OFF</b>			

\*On Single Speed Model Washers, All Speeds are Fast.

KEY:

H = HOT      W = WARM      C = COLD

**TIMER NO. 37927 CYCLE SEQUENCE**

**Cycle Sequence Charts**

**NOTE: Times listed are approximate.**

CYCLE	FUNCTION	WATER TEMP. SELECT	*MOTOR SPEED	TIME (Min. & Sec.)
<b>REGULAR</b>	WASH FILL & AGITATE	H,W,C	FAST	15:00
	SPIN		FAST	1:30
	SPIN & SPRAY	C	FAST	:25
	SPIN		FAST	2:35
	RINSE FILL & AGITATE	W,C	FAST	3:00
	SPIN		FAST	6:00
<b>OFF</b>				3:00
<b>PERMANENT PRESS</b>	WASH FILL & AGITATE	H,W,C	FAST	9:00
	SPIN		SLOW	1:30
	SPIN & SPRAY	C	SLOW	:25
	SPIN		SLOW	2:35
	RINSE FILL & AGITATE	W,C	FAST	3:00
	SPIN		FAST	6:00
<b>OFF</b>				3:00
<b>DELICATE</b>	WASH FILL & SOAK	H,W,C		1:30
	WASH FILL & AGITATE	H,W,C	SLOW	:25
	WASH FILL & SOAK	H,W,C		2:35
	WASH FILL & AGITATE	H,W,C	SLOW	:25
	WASH FILL & SOAK	H,W,C		2:35
	WASH FILL & AGITATE	H,W,C	SLOW	:25
	WASH FILL & SOAK	H,W,C		1:05
	SPIN		SLOW	1:30
	SPIN & SPRAY	C	SLOW	:25
	SPIN		SLOW	2:35
	RINSE FILL & AGITATE	C	SLOW	3:00
	SPIN		SLOW	3:00
<b>OFF</b>				3:00

**\*On Single Speed Model Washers, All Speeds are Fast.**

**KEY:**

**H = HOT      W = WARM      C = COLD**

**TIMER NO. 37929 CYCLE SEQUENCE**

**Cycle Sequence Charts**

**NOTE: Times listed are approximate.**

CYCLE	FUNCTION	WATER TEMP. SELECT	*MOTOR SPEED	TIME (Min. & Sec.)
<b>REGULAR</b>	WASH FILL & AGITATE	H,W,C	FAST	15:00
	SPIN		FAST	1:30
	SPIN & SPRAY	C	FAST	:25
	SPIN		FAST	2:35
	RINSE FILL & AGITATE	W,C	FAST	3:00
	SPIN		FAST	6:00
<b>OFF</b>				3:00
<b>PERMANENT PRESS</b>	WASH FILL & AGITATE	H,W,C	FAST	9:00
	SPIN		FAST	1:30
	SPIN & SPRAY	C	FAST	:25
	SPIN		FAST	2:35
	RINSE FILL & AGITATE	W,C	FAST	3:00
	SPIN		FAST	6:00
<b>OFF</b>				3:00
<b>DELICATE</b>	WASH FILL & SOAK	H,W,C		1:30
	WASH FILL & AGITATE	H,W,C	FAST	:25
	WASH FILL & SOAK	H,W,C		2:35
	WASH FILL & AGITATE	H,W,C	FAST	:25
	WASH FILL & SOAK	H,W,C		2:35
	WASH FILL & AGITATE	H,W,C	FAST	:25
	WASH FILL & SOAK	H,W,C		1:05
	SPIN		FAST	1:30
	SPIN & SPRAY	C	FAST	:25
	SPIN		FAST	2:35
	RINSE FILL & AGITATE	C	FAST	3:00
	SPIN		FAST	3:00
<b>OFF</b>				3:00

**\*On Single Speed Model Washers, All Speeds are Fast.**

**KEY:**

**H = HOT      W = WARM      C = COLD**

**TIMER NO. 200927P CYCLE SEQUENCE**

**Cycle Sequence Charts**

**NOTE: Times listed are approximate.**

CYCLE	FUNCTION	WATER TEMP. SELECT	*MOTOR SPEED	TIME (Min. & Sec.)
<b>SOAK</b>	SOAK FILL & AGITATE	H,W,C	SLOW	4:00
	SOAK FILL	H,W,C		12:00
	SPIN		SLOW	4:00
<b>OFF</b>				4:00
<b>REGULAR</b>	WASH FILL & AGITATE	H,W,C	FAST	15:30
	SPIN		FAST	:24
	RINSE FILL & AGITATE	W,C	FAST	3:37
	SPIN		FAST	1:13
	SPIN & SPRAY	C	FAST	:30
	SPIN		FAST	6:00
<b>OFF</b>				4:00
<b>PERMANENT PRESS</b>	WASH FILL & AGITATE	H,W,C	FAST	9:30
	SPIN		SLOW	:24
	RINSE FILL & AGITATE	W,C	FAST	3:37
	SPIN		FAST	1:13
	SPIN & SPRAY	C	FAST	:30
	SPIN		FAST	6:00
<b>OFF</b>				4:00
<b>DELICATE</b>	WASH FILL & SOAK	H,W,C		1:30
	WASH FILL & AGITATE	H,W,C	FAST	:30
	WASH FILL & SOAK	H,W,C		1:30
	WASH FILL & AGITATE	H,W,C	FAST	:30
	WASH FILL & SOAK	H,W,C		1:30
	WASH FILL & AGITATE	H,W,C	FAST	:30
	WASH FILL & SOAK	H,W,C		1:30
	WASH FILL & AGITATE	H,W,C	FAST	:30
	WASH FILL & SOAK	H,W,C		1:30
	SPIN		SLOW	:24
	RINSE FILL & AGITATE	C	SLOW	3:37
	SPIN		SLOW	1:13
	SPIN & SPRAY	C	SLOW	:30
	SPIN		SLOW	4:00
	<b>OFF</b>			

\*On Single Speed Model Washers, All Speeds are Fast.

KEY:

H = HOT      W = WARM      C = COLD

**TIMER NO. 201101 CYCLE SEQUENCE**

**Cycle Sequence Charts**

**NOTE: Times listed are approximate.**

CYCLE	FUNCTION	WATER TEMP. SELECT	*MOTOR SPEED	TIME (Min. & Sec.)
<b>REGULAR</b>	WASH FILL & AGITATE	H,W,C	FAST	15:00
	SPIN		FAST	:24
	RINSE FILL & AGITATE	W,C	FAST	3:00
	SPIN		FAST	1:00
	SPIN & SPRAY	C	FAST	:30
	SPIN		FAST	6:00
<b>OFF</b>				3:00
<b>PERMANENT PRESS</b>	WASH FILL & AGITATE	H,W,C	FAST	9:00
	SPIN		FAST	:24
	RINSE FILL & AGITATE	W,C	FAST	3:00
	SPIN		FAST	1:00
	SPIN & SPRAY	C	FAST	:30
	SPIN		FAST	6:00
<b>OFF</b>				3:00
<b>DELICATE</b>	WASH FILL & SOAK	H,W,C		1:30
	WASH FILL & AGITATE	H,W,C	FAST	:25
	WASH FILL & SOAK	H,W,C		2:35
	WASH FILL & AGITATE	H,W,C	FAST	:25
	WASH FILL & SOAK	H,W,C		2:35
	WASH FILL & AGITATE	H,W,C	FAST	:25
	WASH FILL & SOAK	H,W,C		1:05
	SPIN		FAST	:24
	RINSE FILL & AGITATE	C	FAST	3:00
	SPIN		FAST	1:00
	SPIN & SPRAY	C	FAST	:30
	SPIN		SLOW	3:00
	<b>OFF</b>			

**\*On Single Speed Model Washers, All Speeds are Fast.**

**KEY:**

**H = HOT      W = WARM      C = COLD**

**TIMER NO. 201100 CYCLE SEQUENCE**